

DESCRIPTION:

The **GEFCO Select #SE133-Series Rotators** are designed for professional built water displays, where continuous rotation of the spray head is expected and propulsion is not by spray jets. The spray heads are mounted on all stainless steel, self cleaning bearing chambers, as well as #SE737-3 adjustment flanges. The spray assemblies shall be installed perfectly vertical, showing only the top parts of the spray jets above water level. The spray heads are made of brass, bronze and copper. There are 3 drive jets, that can be adjusted to control the speed of rotation. The center jet is swivel mounted, peripheral jets can be flow and directional adjusted to suit the design. All single & center jets require non twisting non-turbulent water supply! The use of 100 % filtered water is recommended.

The GEFCO Select #SE133 Series Rotating Jets can be installed on a GEFCO #PE109-Series Slab Penetration which will provide a rigid non-corrosive, water-proofing penetration.

TYPICAL SPECIFICATIONS:

- * **GEFCO Select #SE133 Rotating Jet:**
- made of cast bronze, brass and SST fitted.
- SST bearings
- w/ or w/out 0.625" center jet (specify) *
- 3, 6, 9 or 12 ea. 0.375" jets (specify)
- 3" N.P.T. female connection.

ADDITIONAL INFORMATION:

- Standard diameter is 18", other diameters at extra cost.
- **Suction Straining required to be: MAX. .187"**
- 'OS': Center Jet=.625", Peripheral & Drive Jets=.375"
- *: Single jet is off center 'Lariat' or 'Spiral' type spray effects.
- 'OH': 14.570" - variable due to adjustments.
- 'UT': 11.820" - Rotators are designed to work in perfectly vertical alignment with the given "FH" pressure rating.

IMPORTANT NOTE:

The nozzle pressure must be designed not to exceed 29 feet TDH.

PERFORMANCES: All jets at full height of 'SH'.

#SE133	SH	8Ft.	10Ft.	15Ft.	20Ft.
	FH	11Ft.	14Ft.	19Ft.	28Ft.
	N	GPM	GPM	GPM	GPM
-01	1	44	55	75	99
-02	3	46	58	79	104
-03	3+1	67	84	115	150
-04	6	69	87	118	155
-05	6+1	90	113	154	172
-06	9	84	106	144	189
-07	9+1	105	132	169	236
-08	12	113	144	197	258
-09	12+1	134	171	233	395

IMPORTANT REQUIREMENT

Designers and Engineers shall be responsible for the accuracy of system flow rates and especially system head loss requirements. Stated flows and head pressure requirements for any listed spray height are required AT THE NOZZLE. Extrapolations for unlisted spray heights are at the sole responsibility of the Designers and/or Engineers.

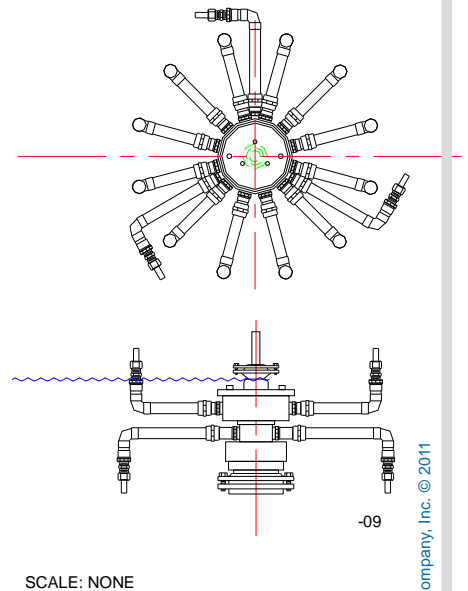
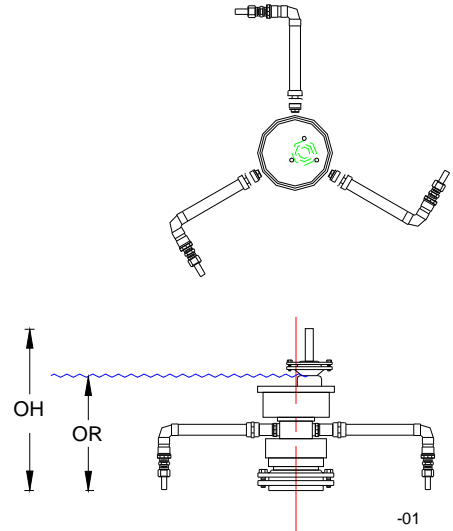

IMPORTANT

Dimensions, Manufacturers and/or Materials subject to change without notice