

DESCRIPTION:

The **GEFCO Select #SE216-2 Fluid Switch Operated Aeration Jet Assembly** is a fluid diverter unit that allows the rapid switching of fluid by non-mechanical means (no valve) in the main water stream. There is only one small solenoid valve that controls the atmospheric pressure inside the switch path way. There are no shocks or water hammer in the water piping. Typical switching speed is an impressive fast 0.1 sec. the performance chart below is for a combination of the GEFCO Select SE#216-2 Fluid Switch operated Aeration Jet Assembly when used with a GEFCO Select #SE112-20 Aeration jet (ordered separately). The GEFCO Select #SE216-2 Fluid Switch operated aeration jet assembly is typically connected directly to a GEFCO #PE109-20 slab penetration or with a high pressure hose to a GEFCO #PE109-20 slab penetration or common water manifold.

The GEFCO Select #SE216-2 Fluid Switch operated Aeration Jet Assembly will operate in open air AS WELL AS TOTALLY SUBMERGED except for the Static Airline and the spray effect jet used. The Control Solenoid Valve is made of ALL SST and can be ordered in operating Voltages of 12 or 24VAC (please specify).

The Main switch body is made of ultraviolet-resistant injection molded ABS Plastic and features a 2" NPT water connection, a 1-1/2" discharge and exhaust to the floor. The GEFCO Select #SE216 Fluid Switch will operate other spray effects as well. Consult the Factory for performances using other jets.

IMPORTANT NOTE:

THE LISTED PERFORMANCE IS ONLY VALID WHEN USING GEFCO SELECT #SE112-20 CASCADE JETS!

TYPICAL SPECIFICATIONS:

- * **GEFCO Select #SE216-2 Fluid Switch Operated Aeration Jet Assembly:**
- 2" NPT Inlet.
- (2)1-1/2" NPT Jet outlet.
- UV Hardened ABS Injection Molded Plastic.
- Submersible 12/24VAC (Specify) SST Solenoid valve, prewired to:
- 9 feet of UL Listed Submersible Cable (ST18/3)
- GEFCO Select #SE112-20 Aeration Jet, Brass
- GEFCO Select #SE137-20 Adjustment Flange, 2" NPT
- GEFCO Custom 1-1/2" Flow straightener.

ADDITIONAL INFORMATION:

- * **Suction Straining required to be: 0.125" MAX.**
- * **ALL PERFORMANCES ARE AT THE JET - NOT AT THE PUMP.**

REPLACEMENT PARTS:

- 1 Solenoid valve coil (specify voltage).
- 2 Solenoid valve diaphragm kit.
- 3 Solenoid valve mounting bolt set.
- 4 Solenoid valve mounting seal kit (O-rings).

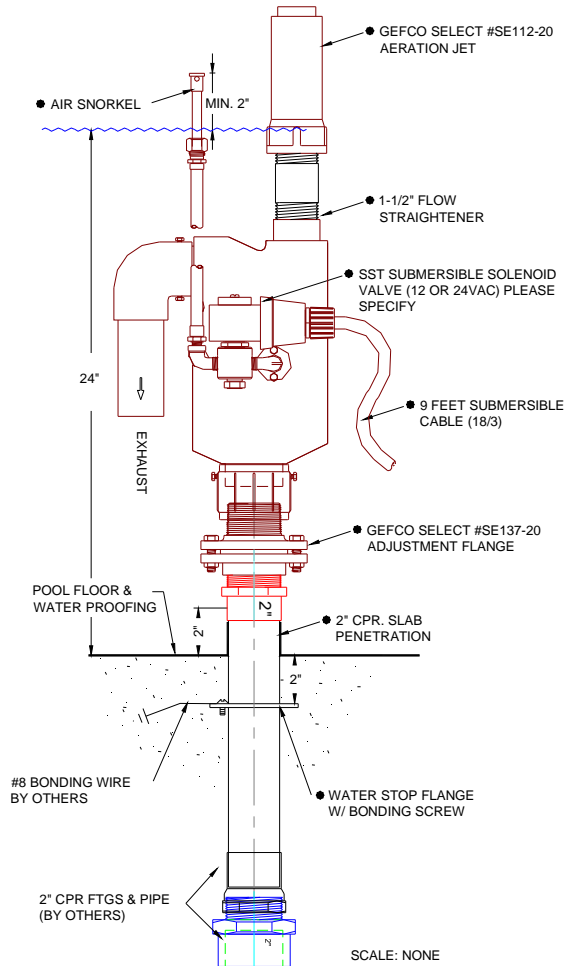

#SE216-2			NEEDED
T	2" NPT		SAFE INFO
DO	1.000"		
OH	22.50"		IN PSI:
SPRAY HEIGHT	GPM	FT. HEAD	EXIT PRESS.
05'	53	60	2.00
06'	60	62	2.60
08'	66	72	3.90
10'	74	86	4.50
12'	77	100	5.50

IMPORTANT REQUIREMENT

Designers and Engineers shall be responsible for the accuracy of system flow rates and especially system head loss requirements. Stated flows and head pressure requirements for any listed spray height are required AT THE NOZZLE. Extrapolations for unlisted spray heights are at the sole responsibility of the Designers and/or Engineers.

IMPORTANT

Dimensions, Manufacturers and/or Materials subject to change without notice